



NEW

MEASURE

- ✓ TORQUE
- ✓ INCLINATION



ACCURATE & EASY TO USE

- 99%+ Accurate Torque Measurement
- In-cab touch 7in screen display

EXPORT DATA LOGGING RECORDS

- Torque, pile depth, angle, date, time & more
- Additional user-defined export fields

SIMPLE INSTALLATION

- Replaces Kelly Bar adaptor or mounts directly onto the drive shaft
- To suit 75mm and 100mm square shafts
- Superior design & engineered for tough conditions

WiFi IN-CAB DISPLAY

- For better and more stable data transfer



NEW REPORTING CAPABILITIES

DIGGA IS PLEASED TO INTRODUCE A NEW WAY OF REPORTING AND EXPORTING DATA

- Reports are exportable directly from the display, either via email using a smartphone with its' hotspot enabled or through the onboard USB port connected to a flash drive.

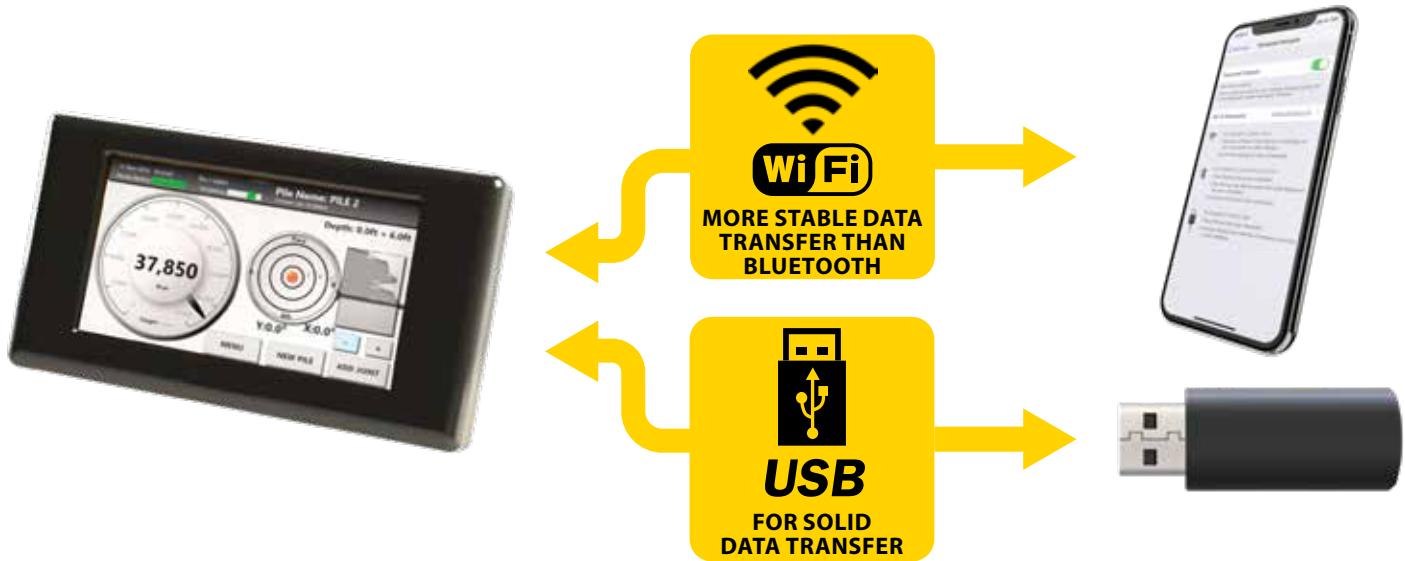

- Reports are exported as both bare data (.dat file – open Excel), and as a PDF line chart as shown below. One cover page for the job and a page for each individual pile is generated.

- Additionally, the PDF line chart will show depth as it is entered during the job. This will give the engineer a view of depth vs. torque on each pile.

An optional handheld trigger is available which allows the operator (or his helper) to depress it when the pile/ anchor reaches a marked depth, allowing a more accurate (and more continuous) representation of torque vs time.

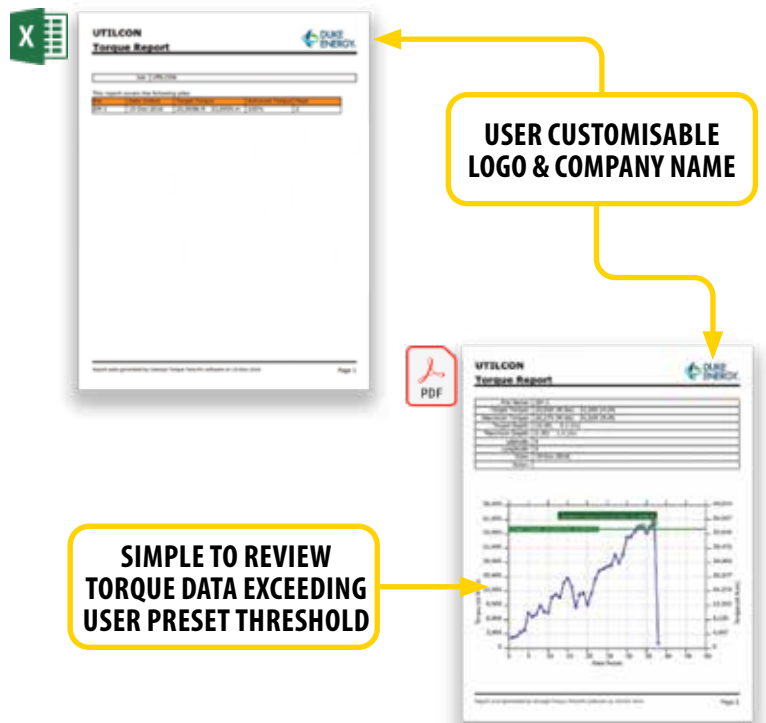



Wireless signal is 2.4 GHz FHSS RF. Outdoor range – up to 4km. Frequency Hopping Spread Spectrum technology allows clear communication across up to 79 frequencies

TORQUE HUB SPECIFICATIONS

Rated Output (R.O.)	2 mV/V nominal
Nonlinearity	0.1% of R.O.
Hysteresis	0.1% of R.O.
Nonrepeatability	0.05% of R.O.
Zero Balance	0.1% of R.O.
Compensated Temp. Range	60° to 160°F
Safe Temp. Range	-65° to 200°F
Temp. Effect on Output	0.005% of Load/°F
Temp. Effect on Zero	0.005% of R.O./°F
Terminal Resistance	350 ohms nominal
Excitation Voltage	5 VDC
Safe Overload	150% of R.O.

7" Windows OS Tablet embedded in a rugged ABS casing. Designed to IP67 ingress protection.

Circuit boards, firmware and software are all designed specific for the application. Fully potted, sealed, gasketed, and cushioned to ensure maximum protection and long life.



Available with 75mm Square and 100mm Square input shafts.

Available with 5-1/4" and 7-5/8" bolt circle flange types.

The heart of the Digga Torque Hub is in the PCB which contains a microprocessor which converts the analog strain gauge input into a digital signal which is transmitted over a robust 2.4 GHz RF signal.

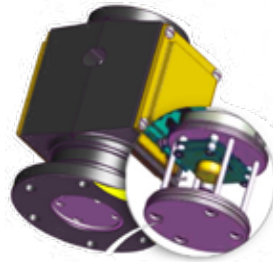

SHAFT TYPE / TORQUE SPECIFICATIONS

SHAFT TYPE	BOLT CIRCLE	TORQUE RATING (MAX.)	"A"	"B"	"C"	WEIGHT
75MM SQ	6 ea—1/2" on 5.25" B.C.	13,558 Nm/ 10,000 ft-lb (5-1/4" BC)	245mm	172mm	24.6mm	33.6Kg
	12 ea—5/8" on 7-5/8" B.C.	27,116 Nm/ 20,000 ft-lb (7-5/8" BC)				
100MM SQ	12 ea—5/8" on 7-5/8" B.C.	27,116 Nm/ 20,000 ft-lb (7-5/8" BC)	290mm	204mm	26.9mm	44Kg
	12 ea—3/4" on 8-5/8" B.C.	94,907 Nm/ 70,000 ft-lb (8-5/8" BC)				

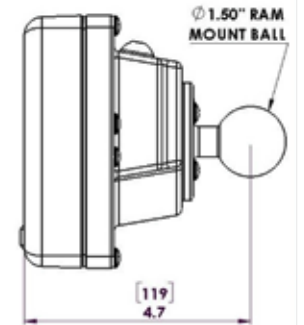
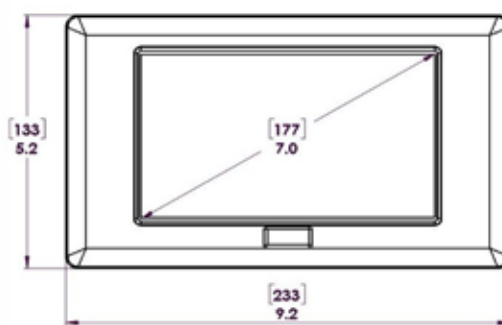
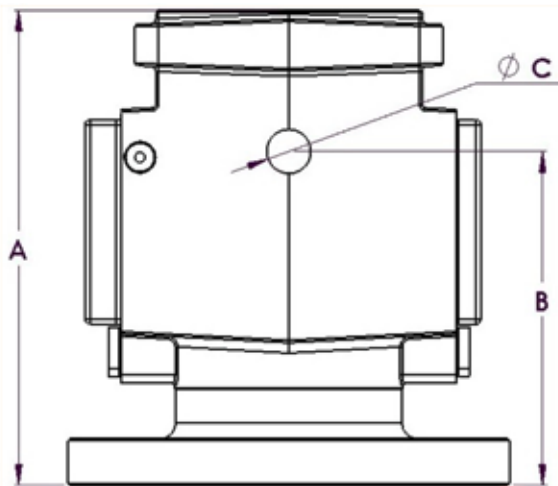

All Torque Hubs are offered double-drilled to accommodate either the 5-1/4", 7-5/8" or 8-5/8" bolt circle on the same hub. Torque ratings remain limited by bolt capacity (13,558.18 Nm, 20,337.27 Nm or 94,907 Nm).